

INSTALLATION INSTRUCTIONS

Alta 1522 Drop-In Dispenser



Release Date: June 12, 2013

Publication Number: 741200028INS

Revision Date: May 9, 2014

Revision: B

Visit the Cornelius web site at www.cornelius.com for all your Literature needs.

The products, technical information, and instructions contained in this manual are subject to change without notice. These instructions are not intended to cover all details or variations of the equipment, nor to provide for every possible contingency in the installation, operation or maintenance of this equipment. This manual assumes that the person(s) working on the equipment have been trained and are skilled in working with electrical, plumbing, pneumatic, and mechanical equipment. It is assumed that appropriate safety precautions are taken and that all local safety and construction requirements are being met, in addition to the information contained in this manual.

This Product is warranted only as provided in Cornelius' Commercial Warranty applicable to this Product and is subject to all of the restrictions and limitations contained in the Commercial Warranty.

Cornelius will not be responsible for any repair, replacement or other service required by or loss or damage resulting from any of the following occurrences, including but not limited to, (1) other than normal and proper use and normal service conditions with respect to the Product, (2) improper voltage, (3) inadequate wiring, (4) abuse, (5) accident, (6) alteration, (7) misuse, (8) neglect, (9) unauthorized repair or the failure to utilize suitably qualified and trained persons to perform service and/or repair of the Product, (10) improper cleaning, (11) failure to follow installation, operating, cleaning or maintenance instructions, (12) use of "non-authorized" parts (i.e., parts that are not 100% compatible with the Product) which use voids the entire warranty, (13) Product parts in contact with water or the product dispensed which are adversely impacted by changes in liquid scale or chemical composition.

Contact Information:

To inquire about current revisions of this and other documentation or for assistance with any Cornelius product contact:

www.cornelius.com

800-238-3600

Trademarks and Copyrights:

This document contains proprietary information and it may not be reproduced in any way without permission from Cornelius.

This document contains the original instructions for the unit described.

CORNELIUS INC
101 Regency Drive
Glendale Heights, IL
Tel: + 1 800-238-3600

Printed in U.S.A.

TABLE OF CONTENTS

Safety Instructions	1
Read and Follow ALL Safety Instructions	1
Safety Overview	1
Recognition	1
Different Types of Alerts	1
Safety Tips	1
Qualified Service Personnel	1
Safety Precautions	2
Shipping And Storage	2
CO2 (Carbon Dioxide) Warning	2
Mounting in or on a Counter	2
Unpacking and Inspection	3
Selecting a Location	4
Installing the Dispenser	4
Drop-In Dispenser	4
Free-Standing Dispenser	4
Preparing for Operation	5
Dispenser Valve Operating Pressure	5
Connecting Product to the Dispenser	5
Programming the Valves	5
Placing the Valve in Programming Mode	5
Cleaning and Maintenance Instructions	6
Daily Cleaning:	6
Daily Maintenance:	6
Monthly Cleaning: (In addition to daily and weekly procedures)	6
Annual Maintenance:	6
Sanitizing Product Cold Plate Tubing	7
Wash Product/Syrup Systems	7
Flush Cooling System	7
Sanitize Cooling System	7
Water Flush the System	8
Purge Water (Restore Operation)	8
Cold Plate Cleaning	8
Cleaning the Ice Bin	8
Cleaning the Product Tubing	8
Sanitize syrup lines, BIB System	9
Replenishing CO2 Supply (As Required)	9

Adjust Water-To-Syrup Ratio	10
Troubleshooting	11
Wiring and Plumbing diagrams	13

SAFETY INSTRUCTIONS

READ AND FOLLOW ALL SAFETY INSTRUCTIONS

Safety Overview

- Read and follow **ALL SAFETY INSTRUCTIONS** in this manual and any warning/caution labels on the unit (decals, labels or laminated cards).
- Read and understand ALL applicable OSHA (Occupational Safety and Health Administration) safety regulations before operating this unit.

Recognition



DIFFERENT TYPES OF ALERTS

DANGER:

Indicates an immediate hazardous situation which if not avoided **WILL** result in serious injury, death or equipment damage.

WARNING:

Indicates a potentially hazardous situation which, if not avoided, **COULD** result in serious injury, death, or equipment damage.

CAUTION:

Indicates a potentially hazardous situation which, if not avoided, **MAY** result in minor or moderate injury or equipment damage.

SAFETY TIPS

- Carefully read and follow all safety messages in this manual and safety signs on the unit.
- Keep safety signs in good condition and replace missing or damaged items.
- Learn how to operate the unit and how to use the controls properly.
- **Do not** let anyone operate the unit without proper training. This appliance is **not** intended for use by very young children or infirm persons without supervision. Young children should be supervised to ensure that they do not play with the appliance.
- Keep your unit in proper working condition and do not allow unauthorized modifications to the unit.

QUALIFIED SERVICE PERSONNEL

WARNING:

Only trained and certified electrical, plumbing and refrigeration technicians should service this unit. **ALL WIRING AND PLUMBING MUST CONFORM TO NATIONAL AND LOCAL CODES. FAILURE TO COMPLY COULD RESULT IN SERIOUS INJURY, DEATH OR EQUIPMENT DAMAGE.**

SAFETY PRECAUTIONS

This unit has been specifically designed to provide protection against personal injury. To ensure continued protection observe the following:

WARNING:

Disconnect power to the unit before servicing following all lock out/tag out procedures established by the user. Verify all of the power is off to the unit before any work is performed.

Failure to disconnect the power could result in serious injury, death or equipment damage.

CAUTION:

Always be sure to keep area around the unit clean and free of clutter. Failure to keep this area clean may result in injury or equipment damage.

SHIPPING AND STORAGE

CAUTION:

Before shipping, storing, or relocating the unit, the unit must be sanitized and all sanitizing solution must be drained from the system. A freezing ambient environment will cause residual sanitizing solution or water remaining inside the unit to freeze resulting in damage to internal components.

CO₂ (CARBON DIOXIDE) WARNING

DANGER:

CO₂ displaces oxygen. Strict attention **MUST** be observed in the prevention of CO₂ gas leaks in the entire CO₂ and soft drink system. If a CO₂ gas leak is suspected, particularly in a small area, **IMMEDIATELY** ventilate the contaminated area before attempting to repair the leak. Personnel exposed to high concentrations of CO₂ gas experience tremors which are followed rapidly by loss of consciousness and **DEATH**.

MOUNTING IN OR ON A COUNTER

WARNING:

When installing the unit in or on a counter top, the counter must be able to support a weight of 200 lbs. to insure adequate support for the unit. **FAILURE TO COMPLY COULD RESULT IN SERIOUS INJURY, DEATH OR EQUIPMENT DAMAGE.**

NOTE: Many units incorporate the use of additional equipment such as icemakers. When any addition equipment is used you must check with the equipment manufacturer to determine the additional weight the counter will need to support to ensure a safe installation.



UNPACKING AND INSPECTION

The unit was thoroughly inspected before leaving the factory and the carrier has accepted and signed for it. Any damage or irregularities should be noted at the time of delivery and immediately reported to the delivery carrier. Request a written inspection report from Claims Inspector to substantiate any necessary claim.

NOTE: IMI Cornelius is not responsible for damaged freight. If damage is found, you must save all packaging material and contact the freight carrier. Failure to contact the carrier within 48 hours of receipt may void your claim.

1. Inspect the carton and note any damage, regardless if it appears minor. If the carton is damaged, note on the consignee copy of the freight invoice "exterior carton damage – concealed damage possible" and contact the freight company immediately.
2. Remove any staples along the bottom edge of the carton and lift the carton off the pallet.
3. Remove the exterior carton sleeve, internal fillers and plastic bag around the unit. Carefully inspect the unit for damage.
4. Remove the bolts holding the dispenser to the pallet.
5. Remove the packing fillers from the top of the unit.
6. Inspect the dispenser cabinet and make sure it has no scratches, dents or any other cosmetic defects.
7. Make sure that the glass or plastic merchandiser panels are not scratched or cracked.
8. Open the packages of loose parts and inspect all of the parts for damage or missing parts. Check the parts received against the packing list to insure receipt of all parts.

SELECTING A LOCATION

The dispenser must be located near a permanent drain to route and connect the unit ice bin and drip tray drain hoses. All drains and connections to such drains must meet local plumbing codes.

The unit must be located near a properly grounded electrical outlet. Circuit should be fused and no other electrical appliance should be connected to the circuit. ALL ELECTRICAL WIRING MUST CONFORM TO NATIONAL AND LOCAL ELECTRICAL CODES.

INSTALLING THE DISPENSER

WARNING:

It is the responsibility of the installer to ensure that the water supply to the dispensing equipment is provided with protection back flow by an air gap as defined in ANSI A 112.1.2-1979; or an approved vacuum breaker or other such method as proved effective by test and must comply with all federal, state and local codes.

Failure to comply could result in serious injury, death or damage to the equipment.

Water pipe connections and fixtures directly connected to a potable water supply shall be sized, installed and maintained according to Federal, State and Local laws.

Drop-In Dispenser

1. Use the Template supplied to mark the location of the hole to be cut into the counter top. Cut the hole as marked and remove the material.
2. Apply the double stick tape (if supplied with the loose shipped parts).

NOTE: To comply with the National Sanitation Foundation (NSF) requirements, the unit must be sealed to the counter top.

3. Liberally apply a sealant, such as Dow Corning RTV 731 or equivalent, to the unit flange bottom surface.
4. Lower the unit into position to complete the seal of the rim to the counter top. Apply additional sealant around the rim to ensure a complete seal.

CAUTION:

Do not move the unit after positioning or the seal may be broken.

5. Remove any excess sealant.
6. Mount the Transformer power supply under the counter, in a position to allow access to the electrical outlet and to allow the 24V power cord to reach the dispenser.
7. Install the drain hose to the ice bin drain fitting and route the drain hose to a permanent drain.

Free-Standing Dispenser

1. Install the 6" legs to the dispenser cabinet if they are to be used.
2. Place the dispenser in the location selected. Be sure the dispenser is level. This is important to ensure that the bin drains properly.
3. Mount the Transformer power supply in a convenient location to allow access to the electrical outlet and to allow the 24V power cord to reach the dispenser.
4. Install the drain hose to the ice bin drain fitting and route the drain hose to a permanent drain.

PREPARING FOR OPERATION

1. Fill the bin with 32° F (0.0° C) ice. DO NOT use ice taken directly from a freezer.
2. Make sure that the cold plate has been chilled for at least 1/2 hour prior to setting the ratio (BRIX), per Pepsi specifications.
3. Start the water booster system according to the suppliers instructions.
4. Turn on the water supply to the unit and pull the relief valve on the carbonator tank, located in bottom of the unit, to assure that the system is flooded with water and all air is removed.
5. Turn off the water supply.
6. Turn on the CO₂ supply. Supply pressure of 110 PSIG from the bulk or high pressure tank to the secondary CO₂ guage.
7. Plug the transformer into the electrical outlet. The 24V supply must be connected in the dispensing tower. The ice-bin lid must be closed to allow the valve to operate.
8. Depress and hold any of the brand buttons that dispense carbonated water until CO₂ only dispenses to purge the system. Now all air is evacuated and the tank is charged with CO₂.
9. Turn on the water supply to the unit.
10. Plug in the pump deck and the motor will run to fill the carb tank with carbonated water.
11. Start up the BIB pumps according to supplier's instructions.
12. Press each brand button individually and hold them open to prime the water and syrup lines. It may take several dispenses until spitting stops and all air has been removed from the water and syrup lines.
13. Set the flow rate for the valve [2-3.75 oz/sec. (59.1-111 cc/sec.)].

DISPENSER VALVE OPERATING PRESSURE

Maximum operating pressure for the valve is 120 PSI (8.27 bar).

CONNECTING PRODUCT TO THE DISPENSER

NOTE: All inlet connections are clearly marked with a label adjacent to the inlet connections. Always leak check all connections.

Valve must have a supply connected to each inlet. Refer to the plumbing diagram for details of the hook-up.

NOTE: A plumbing diagram, when supplied with the unit, can be found in the dispensing tower.

PROGRAMMING THE VALVES

The valves in the Alta 1522 drop-in dispenser may be programmed for dispensing either carbonated water or plain water. Before operating the unit, the installer must enter programming mode to select any plain water valve settings required.

Placing the Valve in Programming Mode

To place the valve in programming mode, press and hold both water buttons and hold them for 5 seconds. This placed the valve in programming mode and allows the setting of the water type for each brand. When the valve enters programming mode, the programming LED illuminates. All valves default to carbonated water on entering programming mode.

To select plain water for a pratically product, the user must press and release the product button. The program LED flashes twice to indicate acceptance.

After 5 seconds without a button press, the valve exits programming mode and saves the water types in memory.

CLEANING AND MAINTENANCE INSTRUCTIONS

WARNING:

Disconnect power to the unit before servicing. Follow all lock out/tag out procedures established by the user. Verify all power is off to the unit before performing any work.

Failure to comply could result in serious injury, death or damage to the equipment.

CAUTION:

Do not use metal scrapers, sharp objects or abrasives on the ice storage hopper, top cover or exterior surfaces as damage to the unit may result. Do not use solvents or other cleaning agents as they may attack the material resulting in damage to the unit.

- **Soap solution** – Use a mixture of mild detergent and warm (100° F) potable water.
- **Sanitizing Solution** – Dissolve 2 packets (4 oz) of Stera Sheen Green Label into 2 gallons of warm [80-100° F (26.7-37.8° C)] potable water to ensure 200 ppm of chlorine.

DAILY CLEANING:

1. Remove cup rest from drip tray and clean with warm soapy water, rinse with clean water and allow to air dry.
2. Wipe down the exterior of the unit with warm, soapy water and rinse with clean, warm water and allow to air dry.
3. Remove valve nozzle and diffuser and wash in warm soapy water, rinse in clean, warm water and allow to air dry.
4. Spray the nozzle and diffuser inside and outside with approved sanitizing solution, reinstall them on the valve and allow to air dry.
5. Pour warm, soapy water down the drains to keep them clean and flowing smoothly.
6. Reinstall the cup rest into the drip tray.
7. Pour all remaining sanitizer solution down the drain to help keep the drain clear.

DAILY MAINTENANCE:

1. Check the temperature, smell and taste of the product.
2. Check the water pressure coming to the unit using the pressure gauges on the back room package.
3. Check carbonation of the drink.
4. Check level of CO₂ supply to the system.
5. Check the date on all of the BIB's (bags in boxes).

MONTHLY CLEANING: (IN ADDITION TO DAILY AND WEEKLY PROCEDURES)

1. Flush and sanitize all syrup lines as well as all of the syrup connectors. (See the sanitize syrup lines section shown later in this manual).
2. Remove the ice from ice bin and clean and sanitize the ice bin. (See the Cleaning the interior surfaces section shown later in this manual).
3. While cleaning the ice bin, use the brush provided with the unit to clean the cold plate surface.

ANNUAL MAINTENANCE:

1. Have the water pump and check valve inspected and cleaned by a qualified service technician.
2. Have the CO₂ gas check valve inspected and cleaned by a qualified service technician.



SANITIZING PRODUCT COLD PLATE TUBING

Preparing the Cleaning Solution: Using a clean tank (tank system) or a five-gallon container (bag-in-box system), prepare a full tank or container of liquid dishwasher detergent by using 70° F (21° C) to 100° F (38° C) potable water and 0.5 oz. (15 ml) of liquid dishwasher detergent (such as Joy, Ivory, etc.) to one gallon of potable water. Shake detergent solution to thoroughly mix the solution.

Preparing the Sanitizing Solution: Using a clean tank (tanks system) or a five-gallon container (bag-in-box system), prepare sanitizing solution using 70° F (21° C) to 100° F (38° C) potable water and 0.5 oz. (15 ml) of household liquid bleach such as non-scented Hi-Lex or Chlorox that contains a 5.25 % sodium hypochlorite concentration to one gallon of potable water. This mixture must not exceed 200 PPM of chlorine. Shake sanitizing solution to thoroughly mix.

Wash Product/Syrup Systems

1. Using a five-gallon container, prepare a container of liquid dishwasher detergent by using 70° F (21° C) to 100° F (38° C) potable water and 0.5 oz. (15 ml) of liquid dishwasher detergent (such as Joy, Ivory, etc.) to one gallon of potable water. Thoroughly mix the solution.
2. Install bag valves (cut from empty bag-in-box syrup containers) on ends of syrup containers syrup outlet tubes connectors.
3. Place all BIB syrup outlet tubes, with bag valves on their ends, in container containing detergent solution.
4. Place waste container under the dispensing valve.
5. Activate the dispensing valve for one minute for each product flavor to purge all syrup and flush out the syrup system.
6. Continue to activate the dispensing valve in cycles (“ON” for 15 seconds, “OFF”, then “ON” for 15 seconds). Repeat “ON” and “OFF” cycles for 15 cycles.
7. Connect detergent solution to remaining syrup systems and flush syrup out of syrup systems as instructed in Step 2.
8. Remove detergent solution source from the syrup system.

Flush Cooling System

1. Fill a five-gallon container with potable water, then place all bag-in-box syrup outlet tubes in the container.
2. Place a waste container under the dispensing valve.
3. Activate the valve for one minute for each product flavor to purge all detergent solution and flush out of the syrup system.
4. Continue to activate the valve in cycles (“ON” for 15 seconds, “OFF”, then “ON” for 15 seconds). Repeat “ON” and “OFF” cycles for 15 cycles.
5. Remove potable water source from the syrup system.

Sanitize Cooling System

1. Using a five-gallon container, prepare sanitizing solution using 70° F (21° C) to 100° F (38° C) potable water and 0.5 oz. (15 ml) of household liquid bleach such as non-scented Hi-Lex or Chlorox that contains a 5.25 % sodium hypochlorite concentration to one gallon of potable water. This mixture must not exceed 200 PPM of chlorine. Thoroughly mix the solution.
2. Place all BIB outlet tubes in the sanitizing solution container.
3. Place a waste container under the dispensing valve.
4. Activate the dispensing valve for one minute for each product flavor to purge all water and install sanitizing solution in the syrup system and dispensing valve.
5. Continue activating the dispensing valve in cycles (“ON” for 15-seconds, “OFF”, then “ON” for 15-seconds). Repeat “ON” and “OFF” cycles for 15-cycles.
6. Remove the sanitizing solution source from the syrup system.

7. Allow sanitizing solution to remain in the syrup systems for not less than 10 or no more than 15 minutes (max.).

Water Flush the System

1. Fill a five-gallon container with potable water.
2. Place all BIB outlet tubes into the potable water container.
3. Place a waste container under the dispensing valve.
4. Activate the dispensing valve for one minute for each product flavor to purge all sanitizing solution out of the syrup system and the dispensing valve.
5. Continue to activate the dispensing valve in cycles (“ON” for 15 seconds, “OFF”, then “ON” for 15 seconds). Repeat “ON” and “OFF” cycles for 15 cycles.
6. Remove the potable water source from the syrup system.

Purge Water (Restore Operation)

1. Remove all bag valves from BIB syrup container outlet tube connectors.
2. Reconnect the BIB containers to the syrup system.
3. Place a waste container under the valve. Dispense from the valve to permit syrup to purge all potable water from the syrup systems and the dispensing valve. Continue to dispense from the valve until only syrup is dispensed from the syrup systems and valve.
4. Repeat Step 3 for all product flavors.

WARNING:

To avoid possible personal injury or property damage, do not attempt to remove the syrup tank cover until CO₂ pressure has been released from the tank.

5. Dispose of waste sanitizing solution in sanitary sewer, not in a storm drain, then thoroughly rinse the inside and outside of the container that was used for sanitizing solution to remove all sanitizing solution residue.

COLD PLATE CLEANING

1. Locate and remove any debris from the drain trough. Check that the drain holes are not clogged.
2. Pour small amount of soap solution on cold plate.
3. Using a cloth, wash down the surfaces of the cold plate with soap solution.
4. Rinse cold plate surface by pouring potable water.

CLEANING THE ICE BIN

1. Prepare a mild detergent soap solution in 100° F (38° C) potable water.
2. Using a nylon (**not wire**) bristle brush, clean the cold plate and the interior of the ice bin with the soap solution.
3. Rinse the cold plate and interior bin surfaces with clean potable water.
4. Using a mechanical spray bottle, prepare a sanitizing solution according to the manufacturer’s directions and spray all of the interior bin surfaces. Allow to air dry.

CLEANING THE PRODUCT TUBING

WARNING:

Only trained and certified electrical, plumbing and refrigeration technicians should service this unit.

All wiring and plumbing must conform to national and local codes. Failure to comply could result in serious injury, death or equipment damage.

Sanitize syrup lines, BIB System

1. Remove all the quick disconnects from all the BIB containers.
2. Fill a suitable pail or bucket with soap solution.
3. Submerge all disconnects (gas and liquid) in the soap solution and then clean them using a nylon bristle brush. **(Do not use a wire brush)**. Rinse with clean water.
4. Using a plastic pail, prepare approximately five gallons of sanitizing solution.
5. Rinse the BIB disconnects in the sanitizing solution.
6. Sanitizing fittings must be attached to each BIB disconnect. If these fittings are not available, the fittings from empty BIB bags can be cut from the bags and used. These fittings open the disconnect so the sanitizing solution can be drawn through the disconnect.
7. Place all the BIB disconnects into the pail of sanitizing solution. Operate the valve until the sanitizing solution is flowing from the valve. Allow sanitizer to remain in lines for 15 minutes.
8. Remove the nozzle and syrup diffuser from the valve and clean them in a soap solution. Rinse with clean water and reassemble the nozzle and syrup diffuser to the valve.
9. Remove the sanitizing fittings from the BIB disconnects and connect the disconnects to the appropriate BIB container. Operate the valve until all sanitizer has been flushed from the system and syrup is flowing freely.

REPLENISHING CO₂ SUPPLY (AS REQUIRED)

NOTE: When indicator on the 1800-psi gage is in the shaded (“change CO₂ cylinder”) portion of the dial, CO₂ cylinder is almost empty and should be changed.



DANGER:

CO₂ displaces oxygen. Strict attention **MUST** be observed in the prevention of CO₂ gas leaks in the entire CO₂ and soft drink system. If a CO₂ gas leak is suspected, particularly in a small area, **IMMEDIATELY** ventilate the contaminated area before attempting to repair the leak. Personnel exposed to high concentrations of CO₂ gas experience tremors which are followed rapidly by loss of consciousness and **DEATH**.

1. Fully close (clockwise) the CO₂ cylinder valve.
2. Slowly loosen the CO₂ regulator assembly coupling nut allowing CO₂ pressure to escape, then remove the regulator assembly from the empty CO₂ cylinder.
3. Unfasten safety chain and remove the empty CO₂ cylinder.



WARNING:

To avoid personnel injury and/or property damage, always secure the CO₂ cylinder with a safety chain to prevent it from falling over. Should the valve become accidentally damaged or broken off, a CO₂ regulator can cause serious personnel injury or death.

4. Position the full CO₂ cylinder and secure with a safety chain.
5. Make sure gasket is in place inside the CO₂ regulator assembly coupling nut, then install the regulator assembly on the CO₂ cylinder.
6. Open (counterclockwise) the CO₂ cylinder valve slightly to allow the lines to slowly fill with gas, then open the valve fully to back-seat the valve (back-seating the valve prevents gas leakage around the valve shaft).
7. Check CO₂ connections for leaks. Tighten any loose connections.

ADJUST WATER-TO-SYRUP RATIO

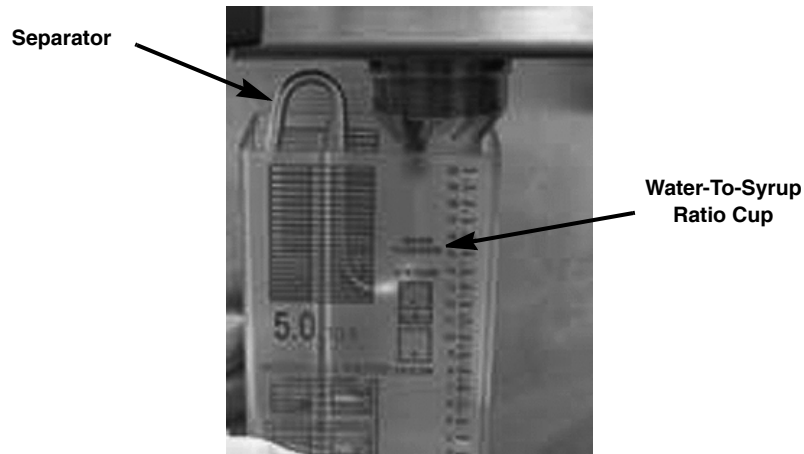

Figure 1. Water to Syrup Ratio Adjustment

1. Remove valve cover and install syrup separator over the diffuser and through the nozzle.
2. Hold cup under valve and dispense beverage for a specific time (i.e. 2 seconds).

NOTE: Water and syrup must be cold before checking ratios.

3. Adjust carbonated water flow to the desired rate [such as 2 to 3 oz. (59 to 88.5 ml) per second].
4. Turn the flow adjuster 1/4 of a turn at a time and recheck the flow. To increase reading turn clockwise.
5. Set syrup flow adjuster to get the desired ratio.
6. Test the valve and adjust until a consistent ratio is delivered three consecutive times.

TROUBLESHOOTING

WARNING:

Only trained and certified electrical, plumbing and refrigeration technicians should service this unit.

All wiring and plumbing must conform to national and local codes. Failure to comply could result in serious injury, death or equipment damage.

Trouble	Probable Cause	Remedy
ADJUSTMENT OF DISPENSING VALVE SYRUP FLOW REGULATOR DOES NOT INCREASE TO DESIRED WATER-TO-SYRUP "RATIO"	A. Dispensing valve syrup flow regulator, BIB quick disconnect, or syrup line restricted. B. BIB quick disconnects not secure. C. Secondary CO ₂ regulator out of adjustment. D. No syrup supply. E. Improper syrup BRIX. F. Dirty or inoperative piston or spring in dispensing valve syrup flow regulator.	A. Sanitize syrup system as instructed. B. Secure quick disconnects. C. Adjust syrup tanks secondary CO ₂ regulator as instructed. D. Replenish syrup supply. E. Replace syrup supply. F. Disassemble and clean dispensing valve syrup flow regulator.
ADJUSTMENT OF DISPENSING VALVE SYRUP FLOW REGULATOR DOES NOT DECREASE TO DESIRED WATER-TO-SYRUP "RATIO"	A. Dirty or inoperative piston or spring in dispensing valve syrup flow regulator.	A. Disassemble and clean dispensing valve syrup flow regulator.
DISPENSED PRODUCT CARBONATION TOO LOW	A. Carbonator primary CO ₂ regulator out of adjustment for existing water conditions or temperature. B. Air in carbonator tank. C. Water, oil, or dirt, in CO ₂ supply.	A. Adjust carbonator primary CO ₂ regulator (Reference manual provided with carbonator). B. Vent air out of carbonator tank through relief valve. Actuate dispensing valve carbonated water lever to make carbonator pump cycle on. C. Remove contaminated CO ₂ . Clean CO ₂ system (lines, regulators, etc.) using a mild detergent. Install a clean CO ₂ supply.
CARBONATED PRODUCT DISPENSED WITH PLAIN WATER	A. Tower not programmed correctly for product.	A. Verify valve programming and correct.
DISPENSED PRODUCT COMES OUT OF DISPENSING VALVE CLEAR BUT FOAMS IN CUP OR GLASS (Continued)	A. Oil film or soap scum in cup or glass. B. Ice used for finished drink is sub-cooled.	A. Use clean cup or glass. B. Do not use ice directly from freezer. Allow ice to become "wet" before using. (Refer to following NOTE).

NOTE: Crushed ice in the glass also causes dispensing problems. When finished drink hits sharp edges of ice, carbonation is released from dispensed drink.



DISPENSED PRODUCT COMES OUT OF DISPENSING VALVE CLEAR BUT FOAMS IN CUP OR GLASS	<ul style="list-style-type: none"> C. Carbonator CO₂ regulator pressure too high for existing water conditions or temperature. D. Syrup over-carbonated with CO₂ as indicated by bubbles in inlet syrup lines leading to unit. E. Warm Product - No ice in bin, bridged ice on cold plate or plugged drain. 	<ul style="list-style-type: none"> C. Reduce carbonator CO₂ regulator pressure setting. Reference manual provided with carbonator. D. Remove BIB quick disconnects. Relieve CO₂ pressure, then relieve CO₂ pressure as many times as necessary to remove over-carbonation. E. Replenish ice, break ice up to eliminate bridging, unplug the drain.
---	--	--

NOTE: If water supply is dirty, be sure to flush lines and carbonator completely. It may be necessary to remove lines to carbonator tank. Invert and flush tank and all inlet lines to remove any foreign particles or dirt.

NO PRODUCT DISPENSED FROM ONE DISPENSING VALVE	<ul style="list-style-type: none"> A. Broken or disconnected wiring. B. Inoperative dispensing valve solenoid coil. C. Inoperative dispensing valve micro switch. 	<ul style="list-style-type: none"> A. Repair or connect wiring. B. Replace solenoid coil as instructed. C. Replace micro switch as instructed.
ONLY CARBONATED WATER DISPENSED	<ul style="list-style-type: none"> A. Quick disconnects not secure on syrup tanks. B. Out of syrup. C. BIB connectors not properly connected. D. Syrup secondary CO₂ regulator not properly adjusted. E. Inoperable dispensing valve. F. Dispensing valve syrup flow regulator not properly adjusted. G. Dispensing valve syrup flow regulator, BIB quick disconnect, or syrup lines restricted. 	<ul style="list-style-type: none"> A. Secure quick disconnects on syrup tanks. B. Replenish syrup supply as instructed. C. Properly attach the connectors. D. Adjust syrup tanks secondary CO₂ regulator as instructed. E. Repair dispensing valve. F. Adjust dispensing valve syrup flow regulator (Water-to-Syrup "Ratio") as instructed. G. Repair regulator, disconnect or lines and sanitize syrup system as instructed.
ONLY SYRUP DISPENSED	<ul style="list-style-type: none"> A. Plain water inlet supply line shutoff valve closed. B. Carbonator power cord unplugged from electrical outlet. C. Carbonator primary CO₂ regulator not properly adjusted. 	<ul style="list-style-type: none"> A. Open plain water inlet supply line shutoff valve. B. Plug carbonator power cord into electrical outlet. C. Adjust carbonator primary CO₂ regulator (Reference manual provided with carbonator).

WIRING AND PLUMBING DIAGRAMS

WIRING DIAGRAM

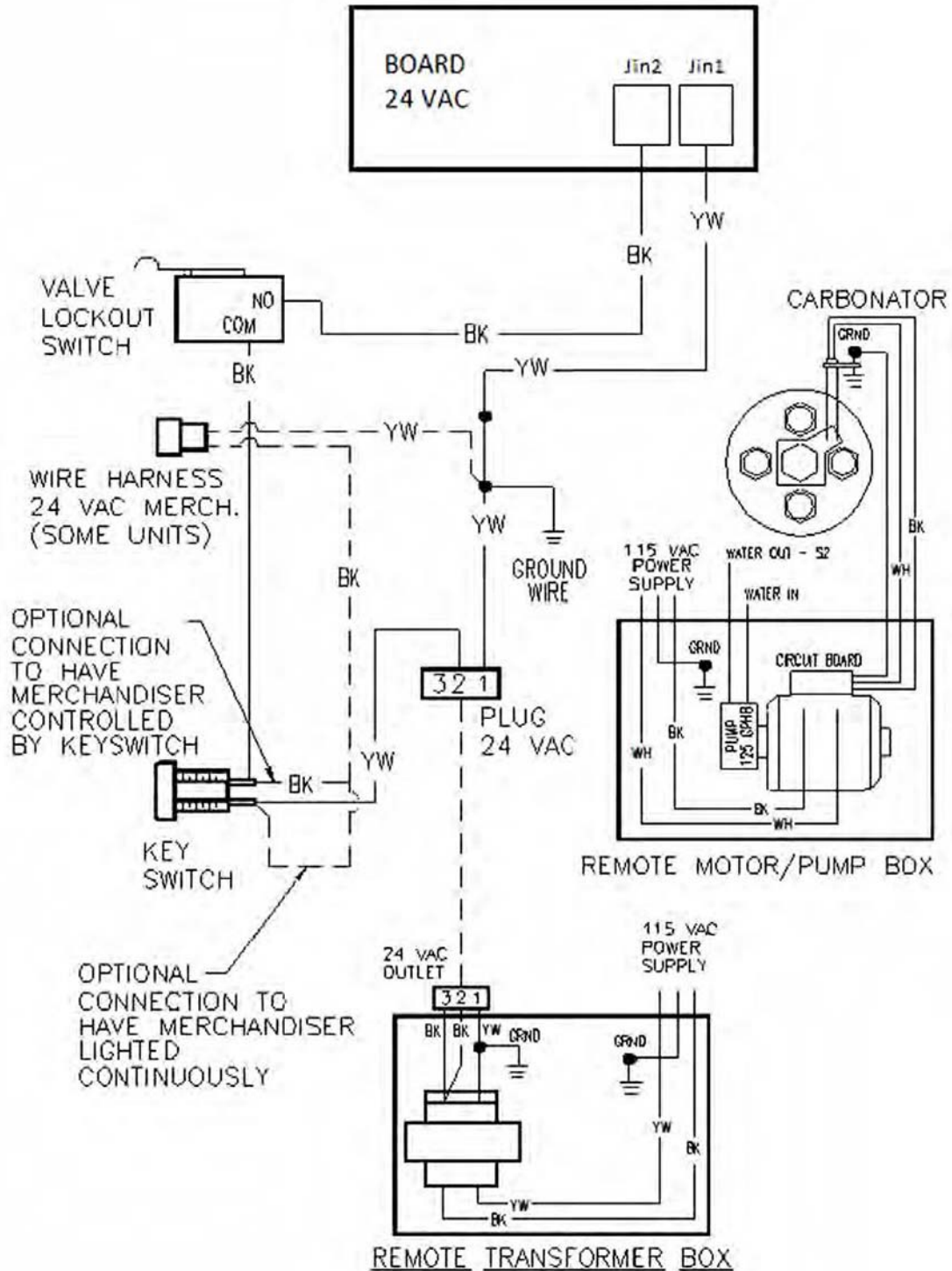

Figure 2. Alta 1522 Drop-in Dispenser Wiring Diagram

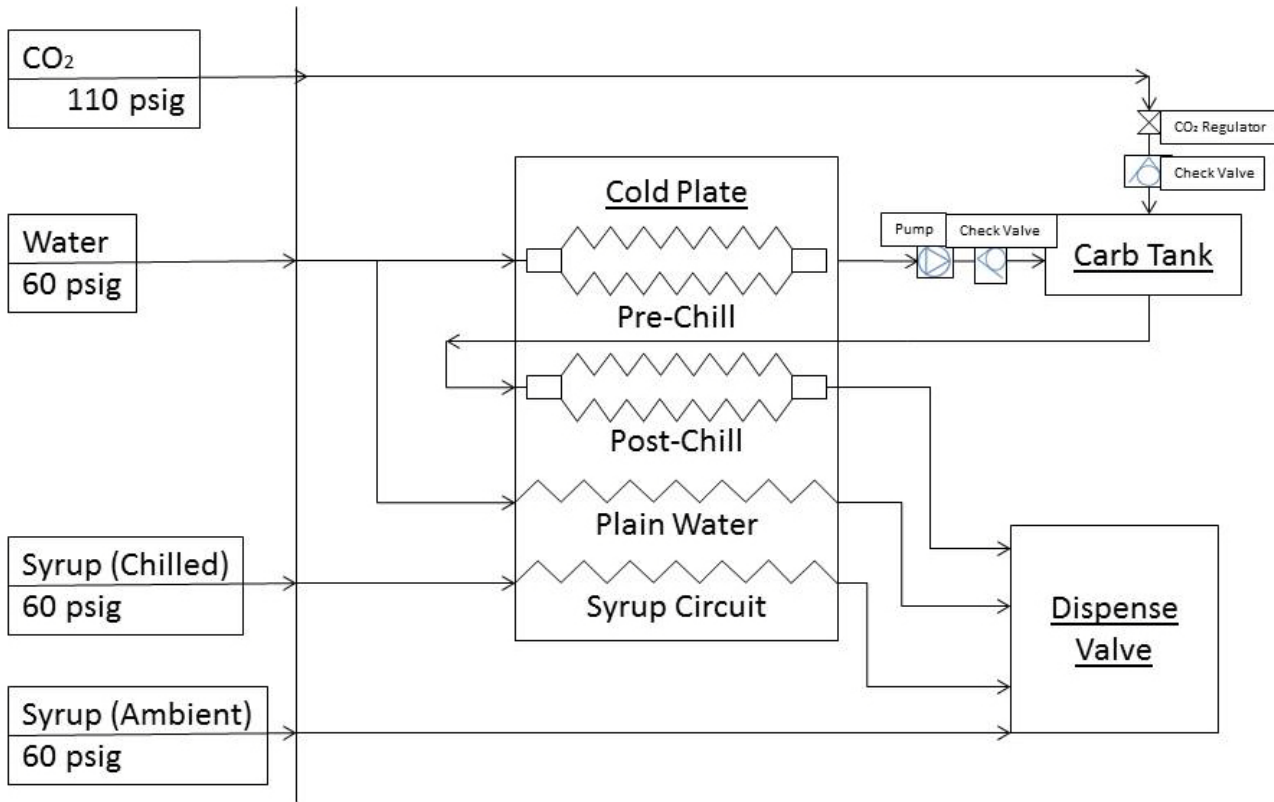

Figure 3. Alta 1522 Drop-in Dispenser Plumbing Diagram

IMI Cornelius Inc.
www.cornelius.com